

# 18年专注于 压力容器法兰制造

18 YEARS OF FOCUS ON  
PRESSURE VESSEL FLANGE  
MANUFACTURING

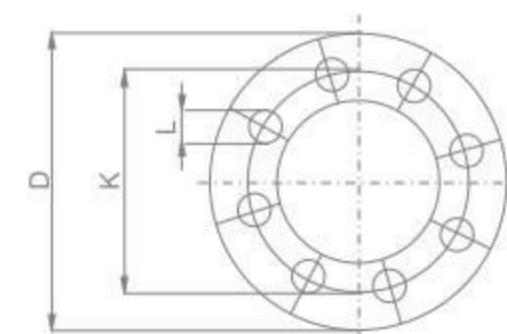

Dimensions of PN 16 Flanges EN 1092-1

Na risbi narisano stevilo luken prikazuje le razpored le the Po delinim krogu. Dejansko stevilo luken je razvidno iz tabele.

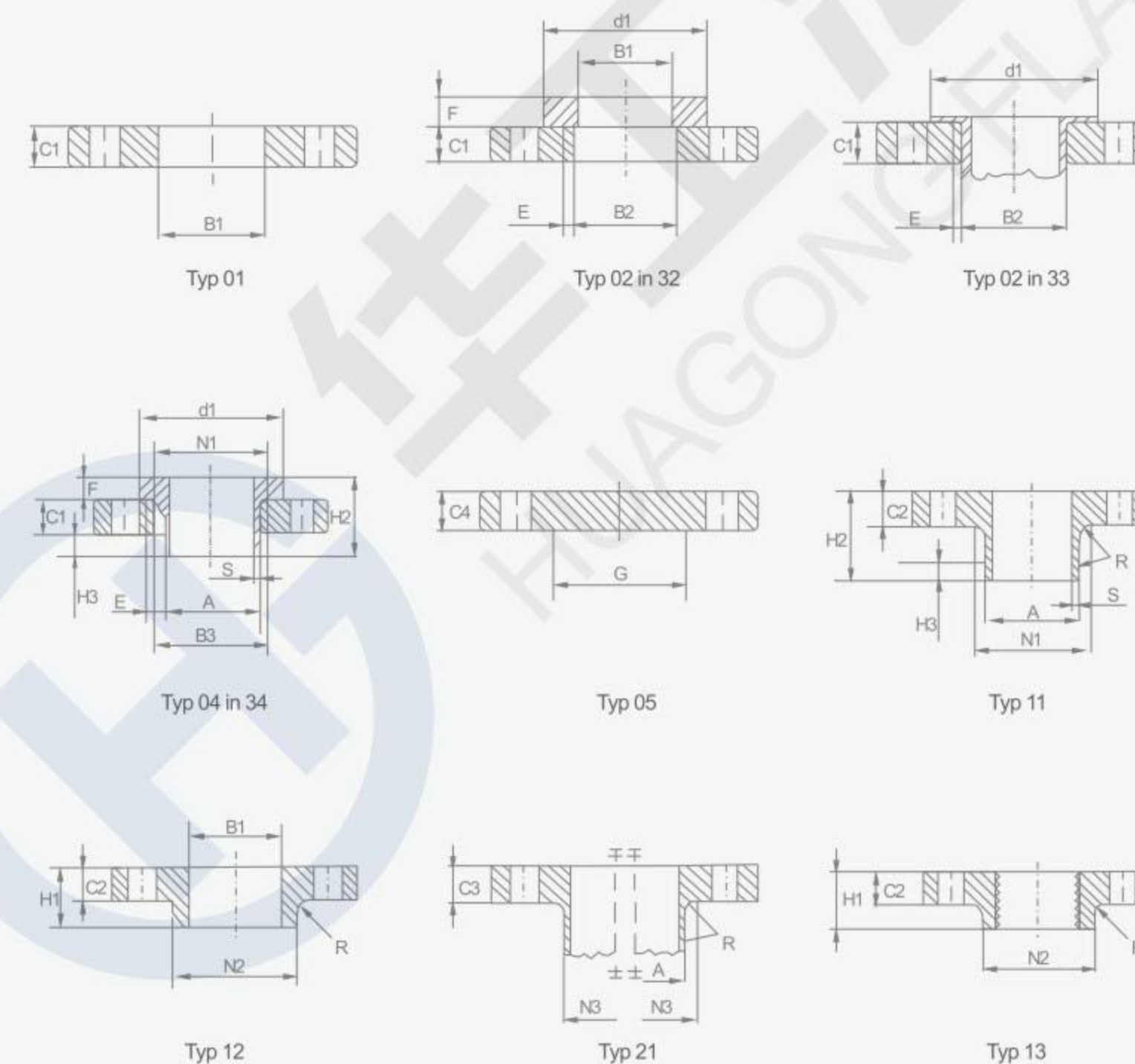

NOTE 1: Dimensions N1, N2 and N3 are measured at the intersection of the hub draft angle and the back face of the flange.

NOTE 2: For d1 dimensions see document "Flange facing according to EN 1092-1".

英标法兰/PN16(BS EN1092-1)

Nominal diameter DN	Mating Dimensions				Bore Diameters	Flange Thickness	Chamfer	Collar Thickness	Diameter Of Shoulders	Length	Neck Diameters	Corner Radius	Neck Thickness (preferred Vallue)											
	Outside Diameter	Diameter Of Bolt Circle	Diameter Of Bolt Hole	Bolting																				
	D	K	L	No Size																				
	A	B1	B2	B3										C1	C2	C3	C4	E	F	G max.	H1	H2	H3	N1
Flange Type																								
01,02,05,11,12,21				11 21 34	01 12 32	02	04	01 02 04	11 12 13	21	05	02 04	32 34	05	12 13	11 34	11 34	11 34	12 13	21	11 12 13 21	11 34		
10	90	60	14	4	M12	17.2	18.0	21	31	14	16	16	16	3	12	-	22	35	6	28	30	28	4	1.8
15	95	65	14	4	M12	21.3	22.0	25	35	14	16	16	16	3	12	-	22	38	6	32	35	32	4	2.0
20	105	75	14	4	M12	26.9	27.5	31	42	16	18	18	18	4	14	-	26	40	6	40	45	40	4	2.3
25	115	85	14	4	M12	33.7	34.5	38	49	16	18	18	18	4	14	-	28	40	6	46	52	52	4	2.6
32	140	100	18	4	M16	42.4	43.5	47	59	18	18	18	18	5	14	-	30	42	6	56	60	60	6	2.6
40	150	110	18	4	M16	48.3	49.5	53	67	18	18	18	18	5	14	-	32	45	7	64	70	70	6	2.6
50	165	125	18	4	M16	60.3	61.5	65	77	19	18	18	18	5	16	-	28	45	8	74	84	84	5	2.9
65	185	145	18	**	M16	76.1	77.5	81	96	20	18	18	18	6	16	55	32	45	10	92	104	104	6	2.9
80	200	160	18	8	M16	88.9	90.5	94	108	20	20	20	20	6	16	70	34	50	10	105	118	120	6	3.2
100	220	180	18	8	M16	114.3	116.0	120	134	22	20	20	20	6	18	90	40	52	12	131	140	140	8	3.6
125	250	210	18	8	M16	139.7	141.5	145	162	22	22	22	22	6	18	115	44	55	12	156	168	170	8	4.0
150	285	240	22	8	M20	168.3	170.5	174	188	24	22	22	22	6	20	140	44	55	12	184	195	190	10	4.5
200	340	295	22	12	M20	219.1	221.5	226	240	26	24	24	24	6	20	190	44	62	16	235	246	246	10	5.9
250	405	355	26	12	M24	273.0	276.5	281	294	29	26	26	26	8	22	235	46	70	16	292	298	296	12	6.3
300	460	410	26	12	M24	323.9	327.5	333	348	32	28	28	28	8	24	285	46	78	16	344	350	350	12	7.1
350	520	470	26	16	M24	355.6	359.0	365	400	35	30	30	30	8	26	330	57	82	16	390	400	410	12	8.0
400	580	525	30	16	M27	406.4	411.0	416	454	38	32	32	32	8	28	380	63	85	16	445	456	458	12	8.0
450	640	585	30	20	M27	457.0	462.0	467	500	42	40	40	40	8	30	425	68	87	16	490	502	516	12	8.0
500	715	650	33	20	M30	508.0	513.5	510	556	46	44	44	44	8	32	475	73	90	16	548	559	576	12	8.0
600	840	770	36	20	M33	610.0	616.5	622	660	52	54	54	54	8	32	575	83	95	18	652	658	690	12	8.8
700	910	840	36	24	M33	711.0	-	-	-	36	42	48	-	-	670	83	100	18	755	760	760	12	8.8	
800	1025	950	39	24	M36	813.0	-	-	-	38	42	52	-	-	770	90	105	20	855	864	862	12	10.0	
900	1125	1050	39	28	M36	914.0	-	-	-	40	44	58	-	-	860	94	110	20	955	968	962	12	10.0	
1000	1255	1170	42	28	M39	1016.0	-	-	-	42	46	64	-	-	960	100	120	22	1058	1072	1076	16	10.0	
1200	1485	1390	48	32	M45	1219.0	-	-	-	48	52	76	-	-	1160	-	130	30	1262	-	1282	16	12.5	
1400	1685	1590	48	36	M45	1422.0	-	-	-	52	58	-	-	-	1346	-	145	30	1465	-	1482	16	14.2	
1600	1930	1820	56	40	M52	1626.0	-	-	-	58	64	-	-	-	1546	-	160	35	1668	-	1696	16	16.0	
1800	2130	2020	56	44	M52	1829.0	-	-	-	62	68	-	-	-	1746	-	170	35	1870	-	1896	16	17.5	
2000	2345	2230	62	48	M56	2032.0	-	-	-	66	70	-	-	-	1950	-	180	40	2072	-	2100	16	20.0	

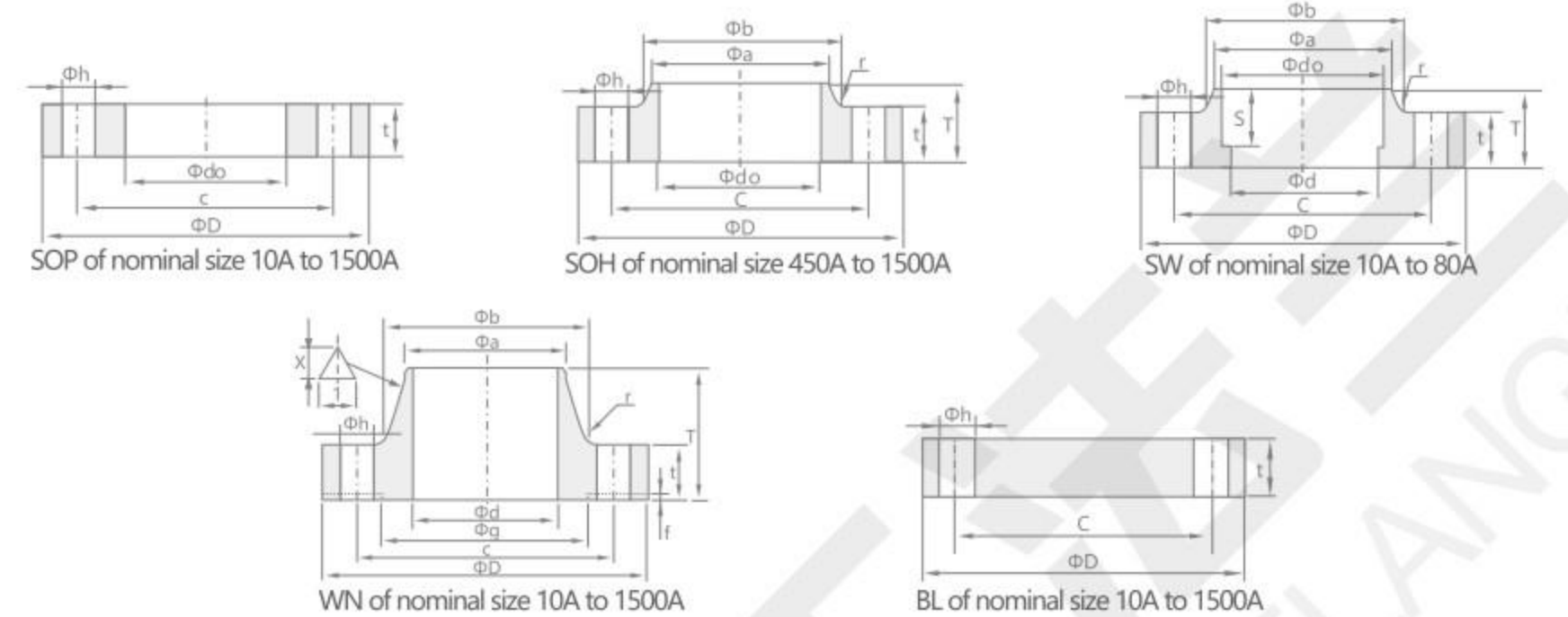

JIS B2220-2012(5K)

口径	法兰外径	法兰内径		法兰厚度		法兰高度		颈小端		颈大端		深度	密封面		连接尺寸		
		SOP SOH SW	SW WN	Except for BL	BL	SOH SW	WN	SOH SW	WN	SOH SW	WN		SW	高度	直径	孔中距	数量
A	D	do	d	t	t	T	T	a	a	b	b	S	f	g	c	n	h
10	75	17.8	12.7	9	9	13	24	23	17.3	26	26	10	1	39	55	4	12
15	80	22.2	16.1	9	9	13	25	27	21.7	30	31	10	1	44	60	4	12
20	85	27.7	21.6	10	10	15	28	33	27.2	36	38	13	1	49	65	4	12
25	95	34.5	27.6	10	10	17	30	41	34.0	44	46	13	1	59	75	4	12
32	115	43.2	35.7	12	12	19	33	50	42.7	53	55	13	2	70	90	4	15
40	120	49.1	41.6	12	12	20	34	56	48.6	60	62	13	2	75	95	4	15
50	130	61.1	52.9	14	14	24	36	69	60.5	73	73	16	2	85	105	4	15
65	155	77.1	67.9	14	14	27	39	86	76.3	91	91	16	2	110	130	4	15
80	180	90.0	80.7	14	14	30	41	99	89.1	105	105	16	2	121	145	4	19
90	190	102.6	93.2	14	14	-	41	-	101.6	-	117	-	2	131	155	4	19
100	200	115.4	105.3	16	16	36	41	127	114.3	130	128	-	2	141	165	8	19
125	235	141.2	130.8	16	16	40	43	154	139.8	161	156	-	2	176	200	8	19
150	265	166.6	155.2	18	18	40	49	182	165.2	189	184	-	2	206	230	8	19
175	300	192.1	180.1	18	18	-	49	-	190.7	-	209	-	2	232	260	8	23
200	320	218.0	204.7	20	20	-	53	-	216.3	-	235	-	2	252	280	8	23
225	345	243.7	229.4	20	20	-	54	-	241.8	-	261	-	2	277	305	12	23
250	385	269.5	254.2	22	22	-	61	-	267.4	-	290	-	2	317	345	12	23
300	430	321.0	304.7	22	22	-	62	-	318.5	-	342	-	3	360	390	12	23
350	480	358.1	339.8	24	24	-	73	-	355.6	-	385	-	3	403	435	12	25
400	540	409.0	390.6	24	24	-	76	-	406.4	-	438	-	3	463	495	16	25
450	605	460.0	441.4	24	24	40	79	495	457.2	500	491	-	3	523	555	16	25
500	655	511.0	492.2	24	24	40	79	546	508.0	552	541	-	3	573	605	20	25
550	720	562.0	543.0	26	26	42	81	597	558.8	603	593	-	3	630	665	20	27
600	770	613.0	593.8	26	26	44	81	648	609.6	654	643	-	3	680	715	20	27
650	825	664.0	644.6	26	28	48	85	702	660.4	708	698	-	3	735	770	24	27
700	875	715.0	695.4	26	30	48	94	751	711.2	758	748	-	3	785	820	24	27
750	945	766.0	746.2	28	32	52	100	802	762.0	810	802	-	3	840	880	24	33
800	995	817.0	797.0	28	34	52	100	854	812.8	862	852	-	3	890	930	24	33
850	1045	868.0	847.8	28	36	54	108	904	863.6	912	902	-	3	940	980	24	33
900	1095	919.0	898.6	30	36	56	108	956	914.4	964	952	-	3	990	1030	24	33
1000	1195	1021.0	1000.2	32	40	60	116	1058	1016.0	1066	1052	-	3	1090	1130	28	33
1100	1305	1122.0	1098.6	32	44	71	136	1158	1117.6	1170	1162	-	3	1200	1240	28	33
1200	1420	1224.0	1200.2	34	48	77	155	1260	1219.2	1272	1272	-	3	1305	1350	32	33
1350	1575	1376.0	1346.2	34	54	80	164	1414	1371.6	1426	1472	-	3	1460	1505	32	33
1500	1730	1529.0	1498.6	36	58	86	172	1568	1524.0	1580	1582	-	3	1615	1660	36	33

备注: (1) 法兰的端面应符合JIS B2202-2004 (2) 根据对接钢管的内径进行调整 (3) 带法兰, 此尺寸供参考 (4) 此值可四舍五入, 尺寸c为半径 (5) 该尺寸可根据有关各方之间的协议来确定

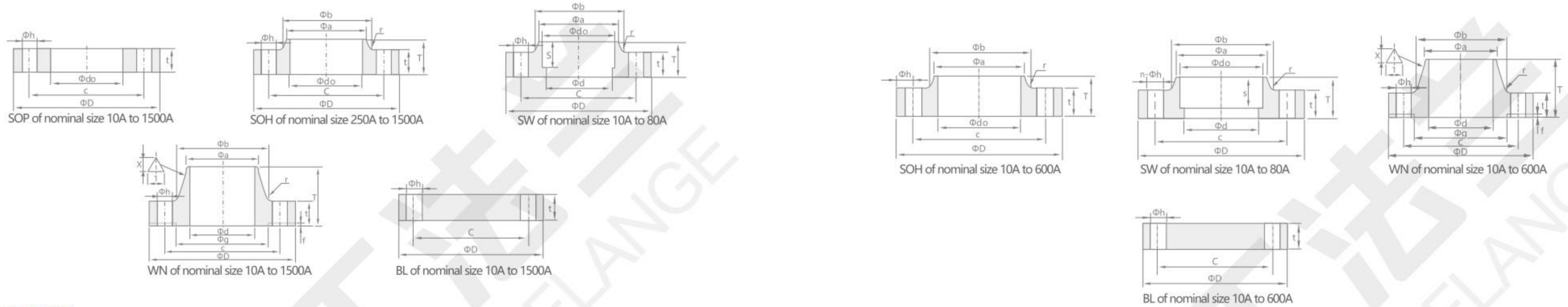

JIS B2220-2012(10K)

(mm)

口径 A	法兰 外径 D	法兰内径		法兰厚度 t	法兰高度		颈小端		颈大端		深度 S	密封面		连接尺寸			
		SOP SOH,SW	SW,WN d		Except for BL	BL	SOH SW	WN	SOH SW	WN		SOH SW	WN	高度	直径	孔中距	数量
		do	d	t	t	T	T	a	a	b	b	S	f	g	c	n	h
10	90	17.8	12.7	12	12	16	29	23	17.3	26	28	10	1	46	65	4	15
15	95	22.2	16.1	12	12	16	31	27	21.7	30	33	10	1	51	70	4	15
20	100	27.7	21.6	14	14	20	32	33	27.2	36	38	13	1	56	75	4	15
25	125	34.5	27.6	14	14	20	36	41	34.0	44	47	13	1	67	90	4	19
32	135	43.2	35.7	16	16	22	38	50	42.7	53	56	13	2	76	100	4	19
40	140	49.1	41.6	16	16	24	38	56	48.6	60	62	13	2	81	105	4	19
50	155	61.1	52.9	16	16	24	40	69	60.5	73	75	16	2	96	120	4	19
65	175	77.1	67.9	18	18	27	44	86	76.3	91	92	16	2	116	140	4	19
80	185	90.0	80.7	18	18	30	45	99	89.1	105	105	16	2	126	150	8	19
90	195	102.6	93.2	18	18	-	45	-	101.6	-	117	-	2	136	160	8	19
100	210	115.4	105.3	18	18	36	45	127	114.3	130	130	-	2	151	175	8	19
125	250	141.2	130.8	20	20	40	47	154	139.8	161	156	-	2	182	210	8	23
150	280	166.6	155.2	22	22	40	53	182	165.2	189	184	-	2	212	240	8	23
175	305	192.1	180.1	22	22	-	55	-	190.7	-	210	-	2	237	265	12	23
200	330	218.0	204.7	22	22	-	58	-	216.3	-	238	-	2	262	290	12	23
225	350	243.7	229.4	22	22	-	58	-	241.8	-	261	-	2	282	310	12	23
250	400	269.5	254.2	24	24	36	65	288	267.4	292	292	-	2	324	355	12	25
300	445	321.0	304.7	24	24	38	68	340	318.5	346	345	-	3	368	400	16	25
350	490	358.1	339.8	26	26	42	79	380	355.6	386	388	-	3	413	445	16	25
400	560	409.0	390.6	28	28	44	85	436	406.4	442	442	-	3	475	510	16	27
450	620	460.0	441.4	30	30	48	90	496	457.2	502	495	-	3	530	565	20	27
500	675	511.0	492.2	30	30	48	99	548	508.0	554	546	-	3	585	620	20	27
550	745	562.0	543.0	32	34	52	111	604	558.8	610	597	-	3	640	680	20	33
600	795	613.0	593.8	32	36	52	112	656	609.6	662	648	-	3	690	730	24	33
650	845	664.0	644.6	34	38	56	116	706	660.4	712	700	-	3	740	780	24	33
700	905	715.0	695.4	34	40	58	132	762	711.2	770	754	-	3	800	840	24	33
750	970	766.0	746.2	36	44	62	139	816	762.0	824	807	-	3	855	900	24	33
800	1020	817.0	797.0	36	46	64	139	868	812.8	876	858	-	3	905	950	28	33
850	1070	868.0	847.8	36	48	66	139	920	863.6	928	908	-	3	955	1000	28	33
900	1120	919.0	898.6	38	50	70	140	971	914.4	979	959	-	3	1005	1050	28	33
1000	1235	1021.0	1000.2	40	56	74	151	1073	1016.0	1081	1065	-	3	1110	1160	28	39
1100	1345	1122.0	1098.6	42	62	95	170	1175	1117.6	1185	1174	-	3	1220	1270	28	39
1200	1465	1224.0	1200.2	44	66	101	182	1278	1219.2	1290	1281	-	3	1325	1380	32	39
1350	1630	1376.0	1346.2	48	74	110	200	1432	1371.6	1450	1438	-	3	1480	1540	36	45
1500	1795	1529.0	1498.6	50	82	123	218	1585	1524.0	1605	1598	-	3	1635	1700	40	45

备注: (1) 法兰的端面应符合 JIS B2202-2004 (2) 根据连接钢管的内径进行调整 (3) 带法兰, 此尺寸供参考 (4) 此值可四舍五入, 尺寸c为半径 (5) 该尺寸可根据有关各方之间的协议来确定

JIS B2220-2012(16K)

(mm)

口径 A	法兰 外径 D	法兰内径		法兰厚度 t	法兰高度		颈小端		颈大端		深度 S	密封面		连接尺寸		
		SOP SOH,SW	SW,WN d		SOH,SW L,TR	WN,IT	SOH,SW L,TR	WN,IT	高度	直径		孔中距	数量	孔径		
		do	d	t	T	T	a	a	b	b	S	f	g	c	n	h
10	90	17.8	12.7	12	16	31	26	17.3	28	29	10	1	46	65	4	15
15	95	22.2	16.1	12	16	32	30	21.7	32	34	10	1	51	70	4	15
20	100	27.7	21.4	14	20	34	38	27.2	42	39	13	1	56	75	4	15
25	125	34.5	27.2	14	20	36	46	34.0	50	47	13	1	67	90	4	19
32	135	43.2	35.5	16	22	39	56	42.7	60	56	13	2	76	100	4	19
40	140	49.1	41.2	16	24	39	62	48.6	66	62	13	2	81	105	4	19
50	155	61.1	52.7	16	24	40	76	60.5	80	75	16	2	96	120	8	19
65	175	77.1	65.9	18	27	46	94	76.3	98	92	16	2	116	140	8	19
80	200	90.0	78.1	20	30	49	108	89.1	112	105	16	2	132	160	8	23
90	210	102.6	90.2	20	-	50	120	101.6	124	118	-	2	145	170	8	23
100	225	115.4	102.3	22	36	56	134	114.3	138	134	-	2	160	185	8	23
125	270	141.2	126.6	22	40	60	164	139.8	170	162	-	2	195	225	8	25
150	305	166.6	151.0	24	40	69	196	165.2	202	192	-	2	230	260	12	25
200	350	218.0	199.9	26	-	73	244	216.3	252	244	-	2	275	305	12	25
250	430	269.5	248.8	28	-	81	304	267.4	312	298	-	2	345	380	12	27
300	480	321.0	297.9	30	-	88	354	318.5	364	352	-	3	395	430	16	27
350	540	358.1	333.4	34	-	104	398	355.6	408	398	-	3	440	480	16	33
400	605	409.0	381.0	38	-	115	446	406.4	456	452	-	3	495	540	16	33
450	675	460.0	431.8	40	-	126	504	457.2	514	510	-	3	560	605	20	33
500	730	511.0	482.6	42	-	128	558	508.0	568	561	-	3	615	660	20	33
550	795	562.0	533.4	44	-	135	612	558.8	622	616	-	3	670	720	20	39
600	845	613.0	584.2	46	-	141	666	609.6	676	670	-	3	720	770	24	39

备注: (1) 法兰的端面应符合 JIS B2202-2004 (2) 根据连接钢管的内径进行调整 (3) 带法兰, 此尺寸供参考 (4) 此值可四舍五入, 尺寸c为半径 (5) 该尺寸可根据有关各方之间的协议来确定

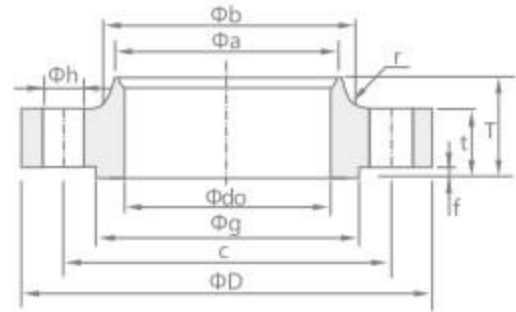

SOH Type A of nominal size 10A to 600A

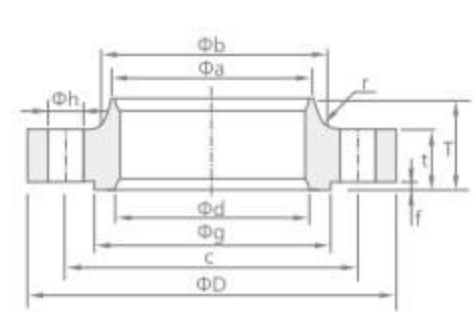

SOH Type B of nominal size 10A to 50A

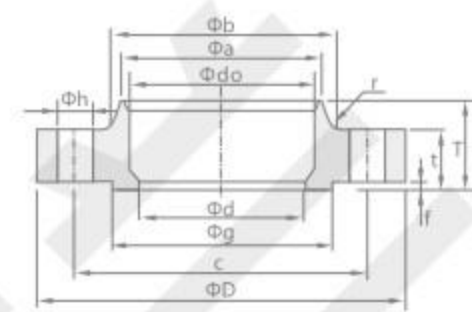

SOH Type C of nominal size 65A to 600A

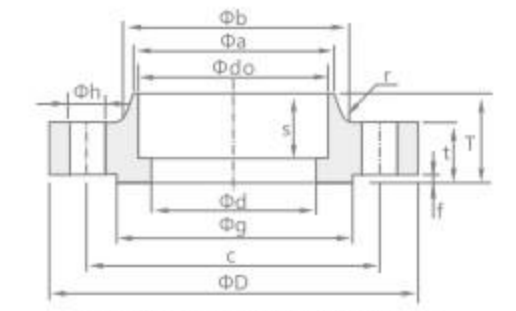

SW of nominal size 10A to 80A

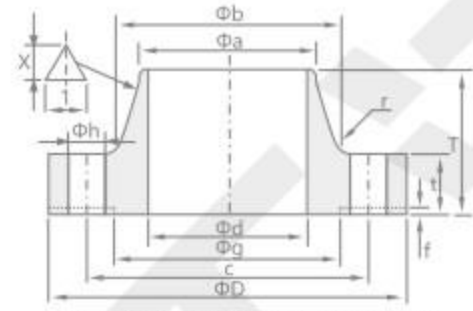

WN of nominal size 10A to 600A

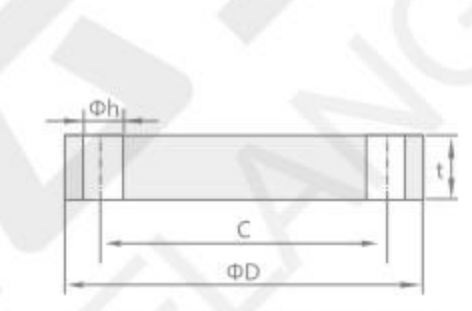

BL of nominal size 10A to 600A

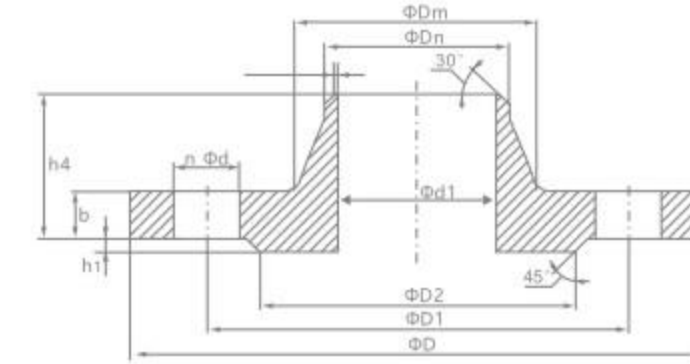

GOST 12820-80 带颈平焊法兰

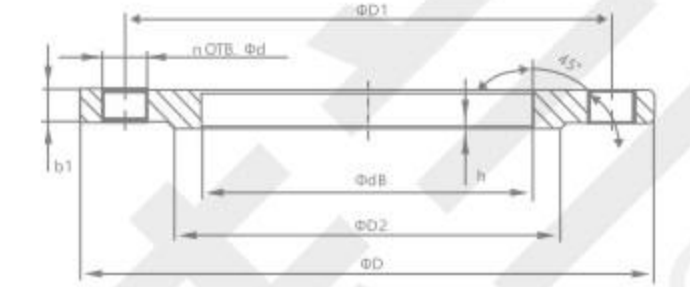

GOST 12821-80 平焊法兰

JIS B2220-2012(20K)

口径	法兰外径	法兰内径		法兰厚度	法兰高度		颈小端		颈大端		深度	密封面		连接尺寸		
		SOH,SW	SOH,SW,WN		SOH,SW,WN,BL	SOH,SW,L,TR	WN	SOH,SW,L,TR	WN,IT	SOH,SW,L,TR		WN,IT	高度	直径	孔中距	数量
A	D	do	d	t	T	T	a	a	b	b	S	f	g	c	n	h
10	90	17.8	12.7	14	20	33	30	17.3	32	29	10	1	46	65	4	15
15	95	22.2	16.1	14	20	34	34	21.7	36	34	10	1	51	70	4	15
20	100	27.7	21.4	16	22	36	40	27.2	42	39	13	1	56	75	4	15
25	125	34.5	27.2	16	24	38	48	34.0	50	47	13	1	67	90	4	19
32	135	43.2	35.5	18	26	41	56	42.7	60	56	13	2	76	100	4	19
40	140	49.1	41.2	18	26	41	62	48.6	66	62	13	2	81	105	4	19
50	155	61.1	52.7	18	26	42	76	60.5	80	75	16	2	96	120	8	19
65	175	77.1	65.9	20	30	48	100	76.3	104	92	16	2	116	140	8	19
80	200	90.0	78.1	22	34	51	113	89.1	117	105	16	2	132	160	8	23
90	210	102.6	90.2	24	36	54	126	101.6	130	118	-	2	145	170	8	23
100	225	115.4	102.3	24	36	58	138	114.3	142	134	-	2	160	185	8	23
125	270	141.2	126.6	26	40	64	166	139.8	172	162	-	2	195	225	8	25
150	305	166.6	151.0	28	42	73	196	165.2	202	192	-	2	230	260	12	25
200	350	218.0	199.9	30	46	77	244	216.3	252	244	-	2	275	305	12	25
250	430	269.5	248.8	34	52	87	304	267.4	312	298	-	2	345	380	12	27
300	480	321.0	297.9	36	56	94	354	318.5	364	352	-	3	395	430	16	27
350	540	358.1	333.4	40	62	110	398	355.6	408	398	-	3	440	480	16	33
400	605	409.0	381.0	46	70	123	446	406.4	456	452	-	3	495	540	16	33
450	675	460.0	431.8	48	78	134	504	457.2	514	510	-	3	560	605	20	33
500	730	511.0	482.6	50	84	136	558	508.0	568	561	-	3	615	660	20	33
550	795	562.0	533.4	52	90	143	612	558.8	622	616	-	3	670	720	20	39
600	845	613.0	584.2	54	96	149	666	609.6	676	670	-	3	720	770	24	39

备注: (1) 法兰的端面应符合JIS B2202-2004 (2) 根据封头管的内径进行调整 (3) 带颈法兰, 此尺寸供参考 (4) 此值可四舍五入, 尺寸c为半径 (5) 该尺寸可根据有关各方之间的协议来确定

口径	法兰外径	法兰内径		密封面			孔径	孔中距	颈小端	法兰颈	螺栓孔数量 n (个)	法兰厚度		法兰高度	重量 (kg)		
		Dy	D	d1	dB	D2						h	h1		d	D1	Dn
15	95	12	19	47	2	3		65	19	30	4	12	12	33	0.61	0.68	
20	105	18	26	58	2	3	14	75	26	38		14	12	36	0.86	0.87	
25	115	25	33	68	2	3		85	33	45		16	12	38	1.17	1.05	
32	135	31	39	78	2	3		100	39	55		16	13	40	1.58	1.54	
40	145	38	46	88	3	4		110	46	64	17	13	42	1.96	1.85		
50	160	49	59	102	3	4		125	59	76	19	13	45	2.58	2.28		
65	180	66	78	122	3	4	18	145	78	94	21	15	47	3.42	3.19		
80	195	78	91	133	3	4		160	91	110	21	17	50	3.71	4.21		
100	215	98	110	158	3	4		180	110	130	8	23	17	50	4.73	4.90	
125	245	121	135	184	3	4		210	135	156		25	19	57	6.38	6.75	
150	280	146	161	212	3	4		240	161	180		25	19	57	7.81	8.30	
200	335	202	222	268	3	4	22	295	222	240		27	21	58	10.1	11.79	
250	405	254	273	320	3	4		355	273	292	12	28	23	65	14.49	17.36	
300	460	303	325	370	4	5	26	410	325	346		28	24	66	17.78	22.76	
350	520	351	377	430	4	5		470	377	400		16	30	28	70	22.88	32.04
400	580	398	426	482	4	5	30	525	426	450			34	32	75	31	43.00
500	710	501	530	585	4	5	33	650	530	559	20	44	38	90	57.01	70.97	
600	840	602	630	685	5	6	36	770	636	660		45	41	90	80.03	99.30	
800	1020	-	820	905	5	-	39	950	820	-	24	49	-	-	104.41	-	
1000	1255	-	1020	1110	5	-	45	1170	1020	-	28	58	-	-	179.37	-	
1200	1485	-	1220	1330	5	-	52	1390	1220	-	32	71	-	-	297.78	-	

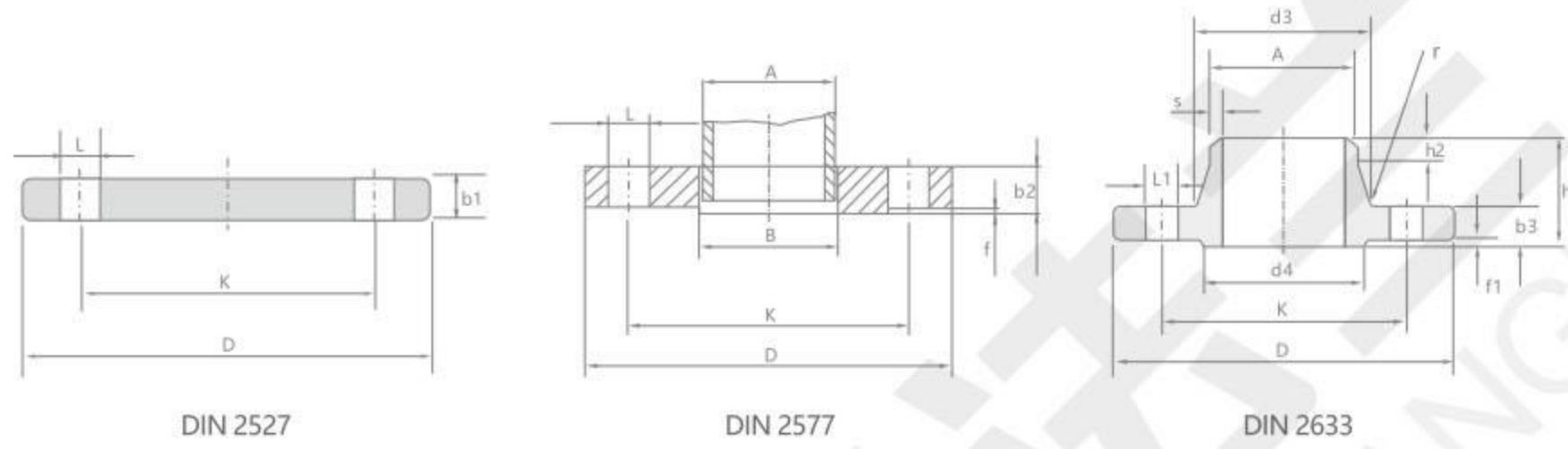

(mm)

公称 口径 DN	管子 外径 A	法兰 外径 D	螺栓孔中 心圆直径 K	螺栓 孔径 L	螺栓		密封面			法兰厚度			法兰内径 2577 B	法兰颈				法兰 高度 h1
					数量 n	螺栓 Th·	d	f	f1	b1	b2	b3		d3	s	r	h2	
10	17.2	90	60	14	4	M12	41	2	2	14	14	14	18.0	28	1.8	4	6	35
15	21.3	95	65	14	4	M12	46	2	2	14	14	14	22.0	32	2.0	4	6	35
20	26.9	105	75	14	4	M12	56	2	2	16	16	16	27.5	40	2.3	4	6	38
25	33.7	115	85	14	4	M12	65	3	2	16	16	16	34.5	45	2.6	4	6	38
32	42.4	140	100	18	4	M16	76	3	2	16	18	16	43.5	56	2.6	6	6	40
40	48.3	150	110	18	4	M16	84	3	3	16	18	16	49.5	64	2.6	6	7	42
50	60.3	165	125	18	4	M16	99	3	3	18	20	18	61.5	75	2.9	6	8	45
65	76.1	185	145	18	4	M16	118	3	3	18	20	18	77.5	90	2.9	6	10	45
80	88.9	200	160	18	8	M16	132	3	3	20	20	20	90.5	105	3.2	8	10	50
100	114.3	220	180	18	8	M16	156	3	3	20	22	20	116.0	131	3.6	8	12	52
125	139.7	250	210	18	8	M16	184	3	3	22	22	22	141.5	156	4.0	8	12	55
150	168.3	285	240	22	8	M20	211	3	3	22	24	22	170.5	184	4.5	10	12	55
200	219.1	340	295	22	12	M120	266	3	3	24	26	24	221.5	235	5.9	10	16	62
250	273.0	405	355	26	12	M24	319	3	3	26	29	26	276.5	292	6.3	12	16	70
300	323.9	460	410	26	12	M24	370	4	4	28	32	28	327.5	344	7.1	12	16	78
350	355.6	520	470	26	16	M24	429	4	4	30	35	30	359.0	390	8.0	12	16	82
400	406.4	580	525	30	16	M27	480	4	4	32	38	32	411.0	445	8.0	12	16	85
450	457.0	640	585	26	20	M27	548	4	-	-	42	-	462.0	131	3.6	8	12	52
500	508.0	715	650	33	20	M30	609	4	4	36	46	34	513.5	548	8.0	12	16	90
600	610.0	840	770	36	20	M33	720	5	5	38	52	36	616.5	652	8.8	12	18	95

华工法兰有限公司  
HUAGONG FLANGE CO., LTD.



扫码咨询



企业官网

地址: 浙江省温州市龙湾区永兴街道滨海园区三道三路593号  
手机: 15868558788 13758706941 13957758975  
电话: 0577-8685 8155  
传真: 0577-8685 1955  
邮箱: 165683284@qq.com  
网址: www.huagongflange.com

Address: No. 593, 3rd Road, 3rd Road, Binhai Park, Yongxing Street,  
Longwan District, Wenzhou City, Zhejiang Province  
Mobile: 15868558788 13758706941 13957758975  
Tel: 0577-8685 8155  
Fax: 0577-8685 1955  
E-mail: 165683284@qq.com  
Web: www.huagongflange.com